

# Light Shelf

---

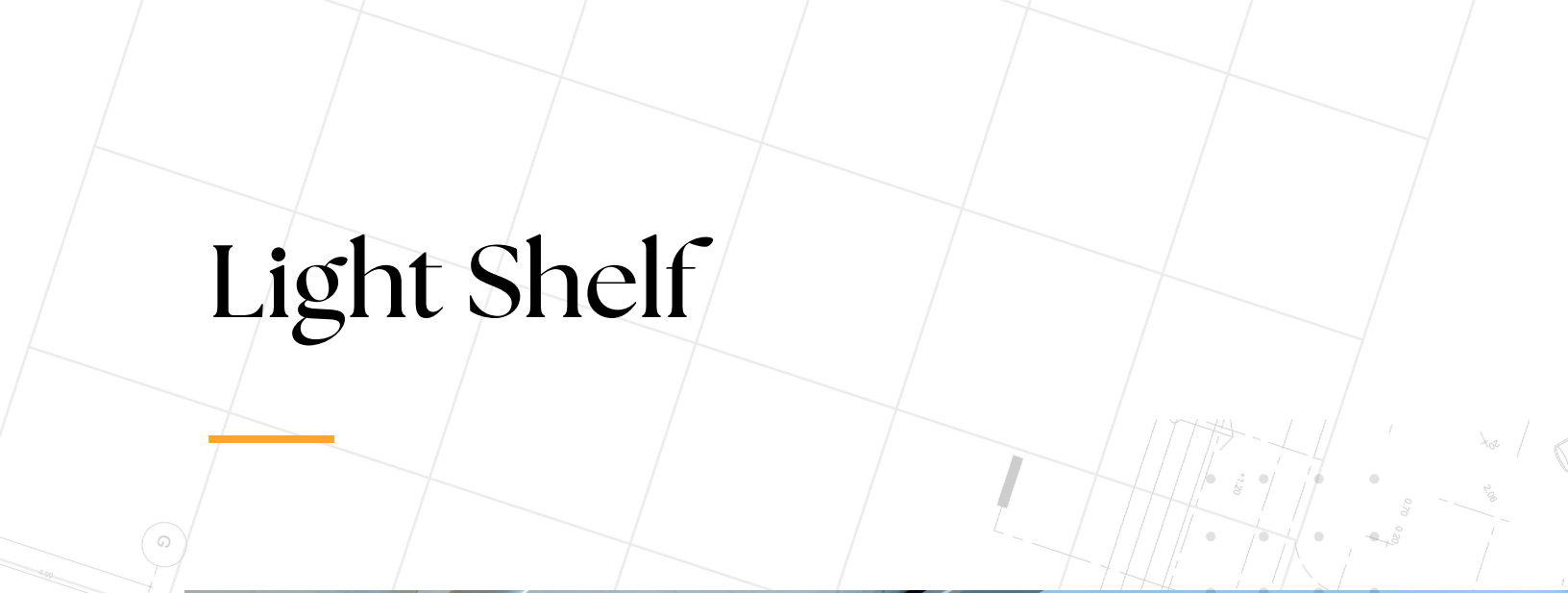



# Light Shelf Automated Light Management System

## Features & Benefits

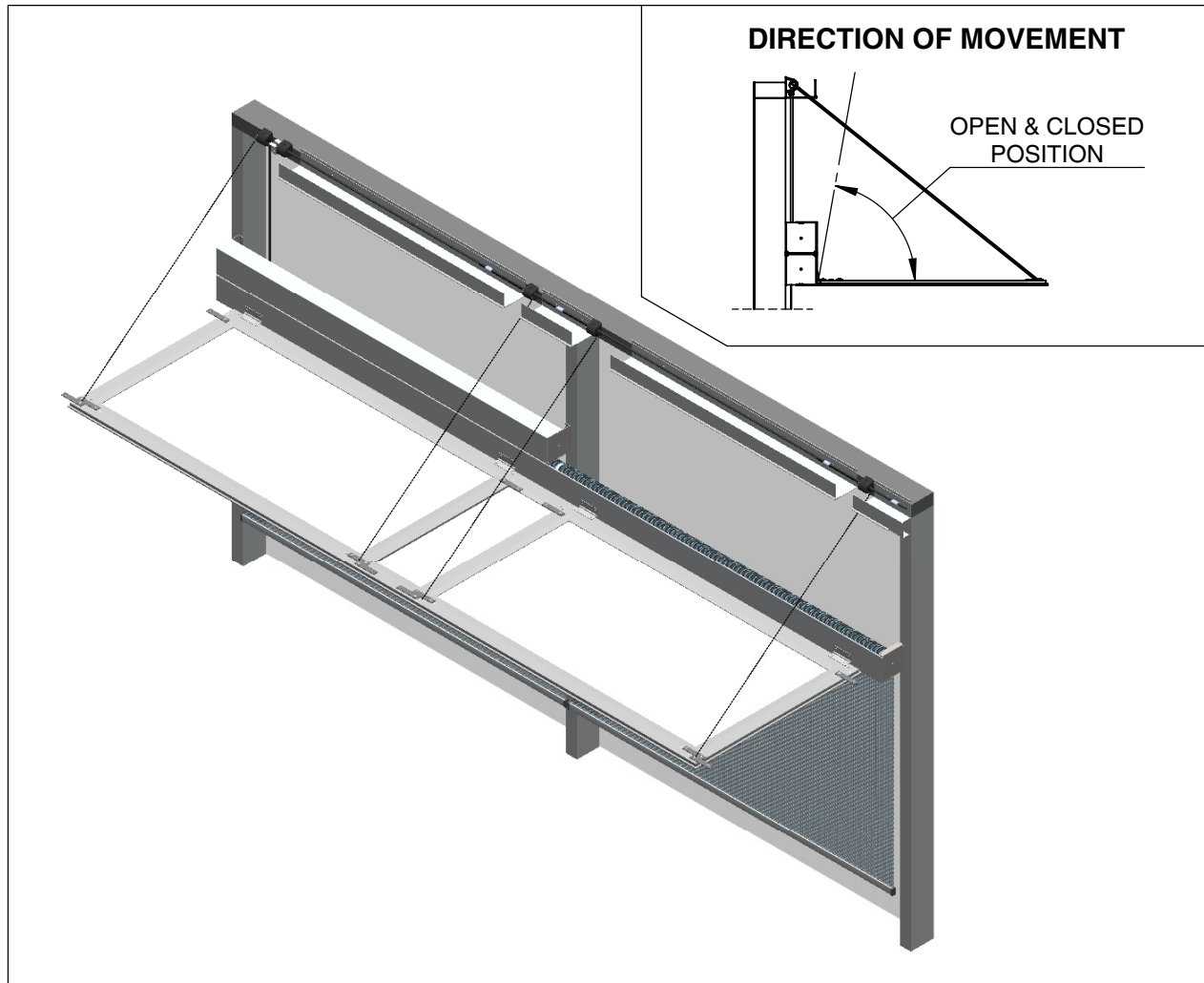

FEATURES		BENEFITS							
DAYLIGHT CONTROL		LIGHT SHELF CAN BE POSITIONED TO OPTIMIZE THE AMOUNT OF LIGHT THAT ENTERS AN INTERIOR SPACE							
ALUMINUM FRAME DESIGN		ABLE TO ACHIEVE WIDER WIDTH PANELS							
POLYCARBONATE MATERIAL		LIGHT WEIGHT AND OFFERS FLEXIBLE LIGHT MANAGEMENT							
ALUMINUM AIRCRAFT CABLE		STRONG AIRCRAFT CABLE PROVIDES A SMOOTH AND EFFORTLESS MOTION WHEN OPERATING THE LIGHT SHELF							
MOTORIZED		INTEGRATED INTO BUILDING MANAGEMENT SYSTEM							
INSERT (OPTIONAL)		INSERT BETWEEN EACH SHELF HELPS SHELF OPERATE TOGETHER AND CAN BE REMOVED FOR A DEMISING WALL IF NECESSARY							
TOP CABLE COVER (OPTIONAL)		CABLE COVER HIDES AIRCRAFT CABLE AND PROVIDES A FINISHED LOOK							
SCALE:	NONE	DWG NUMBER:	LS-M-01	DATE:	OCTOBER 7, 2015	REV:	0	DRAWN BY:	M.E.



# Light Shelf Automated Light Management System

Top Cable Cover (Optional)

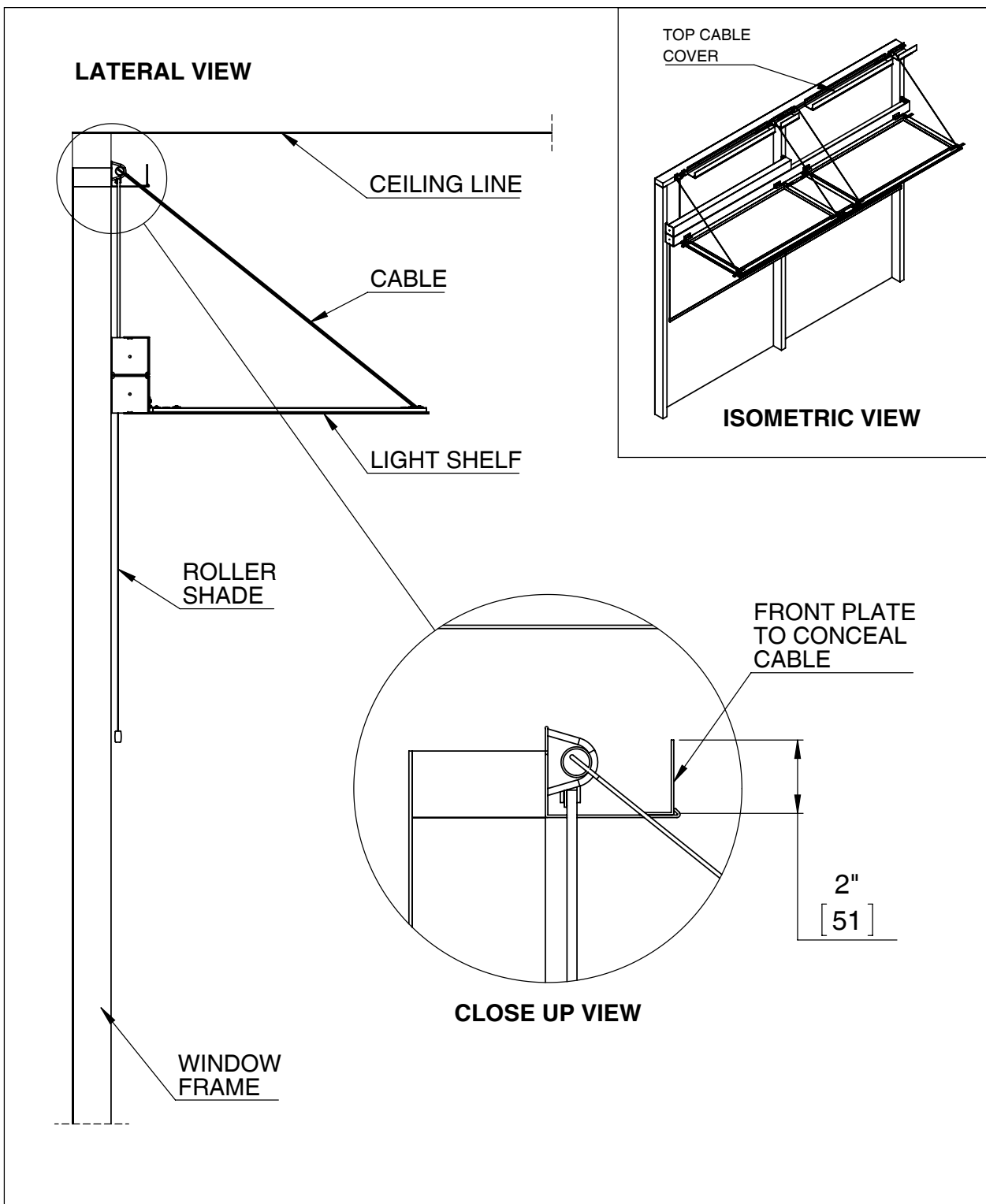

SCALE:	NONE	DWG NUMBER:	LS-FC-PLATE	DATE:	SEPTEMBER 30, 2015	REV:	1	DRAWN BY:	M.E.
--------	------	-------------	-------------	-------	--------------------	------	---	-----------	------



# Light Shelf Automated Light Management System

Daylighting

## DOWN POSITION

LATERAL VIEW

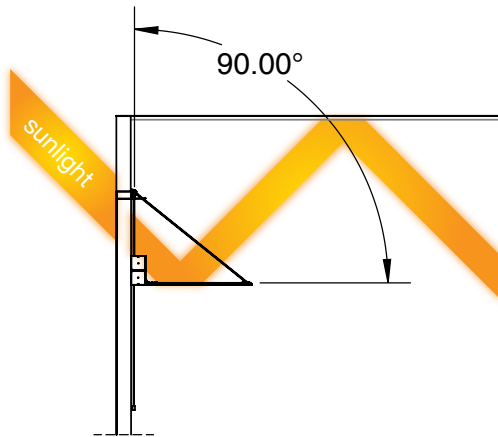

ISOMETRIC VIEW

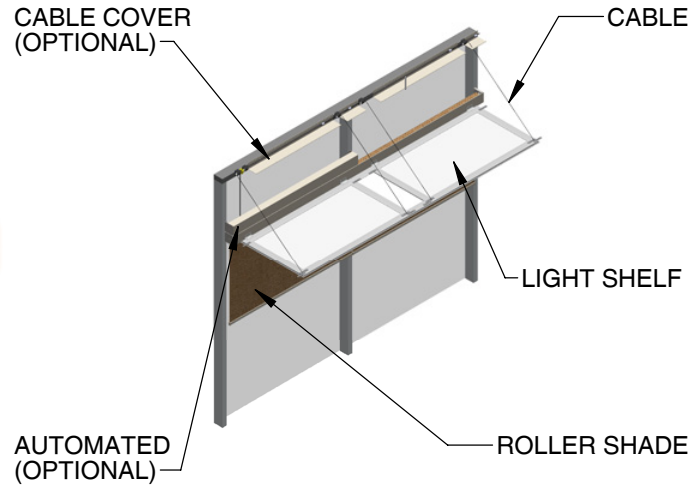

## UP POSITION

LATERAL VIEW

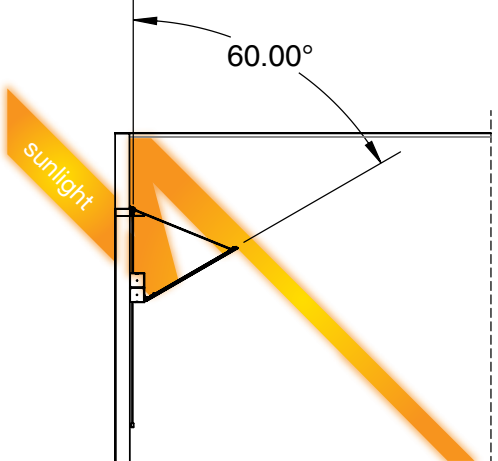

ISOMETRIC VIEW

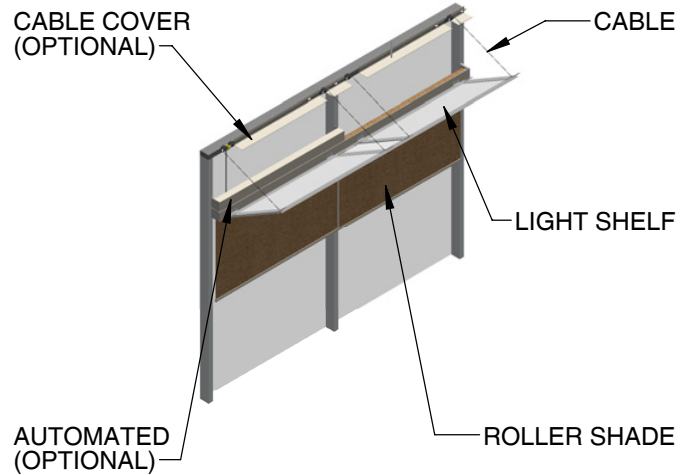

SCALE:	NONE	DWG NUMBER:	LSH-DL-01	DATE:	FEBRUARY 5, 2015	REV:	1	DRAWN BY:	M.E.
--------	------	-------------	-----------	-------	------------------	------	---	-----------	------