

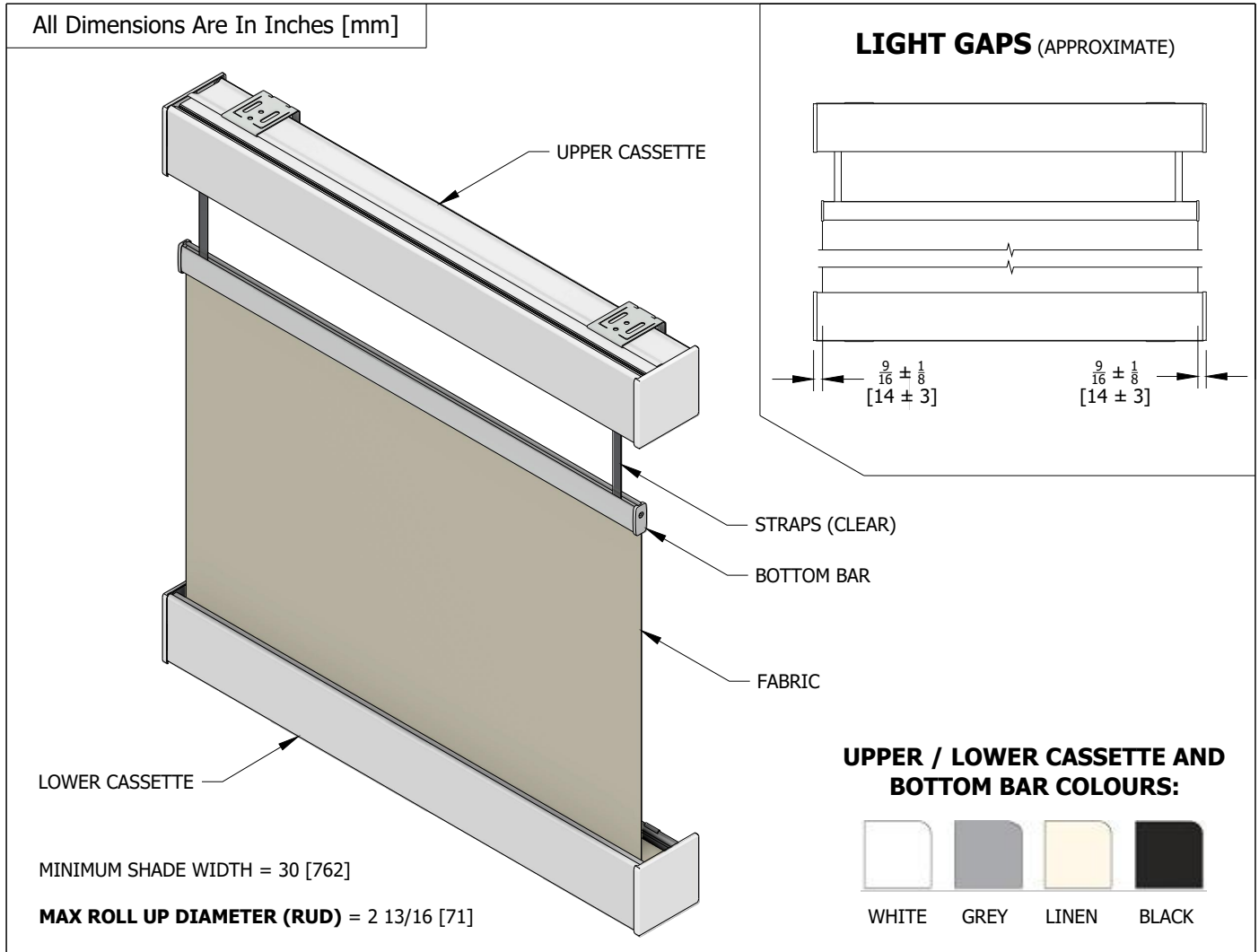

# ROLLER SHADE SYSTEM

## ATLAS 2.0

### FEATURES & BENEFITS



FEATURES	BENEFITS
Flexible Brackets	Snap on zinc plated mounting brackets can be ceiling or wall mounted.
Hight Tension Straps (Clear)	Provide an even look with a long life expectancy while under tension. Clear Straps are non-intrusive if left exposed. Straps are UV resistant for lasting performance.
Colour Matching Options	Provides a finished look for outside wall mounted applications (cassette colours match the bottom bar colours).
Fully Assembled System	Completely assembled unit conceals the roller shade from the interior and exterior space. Fabric drops from the front of the roll in a reverse roll fashion.
Smooth Under Tension Operation	The Upper Cassette is motorized and allows the user to adjust the shade position. The Lower Cassette has balanced springs to help prevent unwanted stress on other shade components while keeping the fabric taut. Combined both increases the longevity of the entire shade system.
Automation Options	Allows for motorized controls with wireless remotes, switches or other smart devices. Compatible with SG Stealth motors and Somfy motors.

SCALE:	1:10	DWG #:	AT2.0-F&B-SG-01	DATE:	2024-06-04	BY:	Matt Ellis	REV:	1
--------	------	--------	-----------------	-------	------------	-----	------------	------	---