

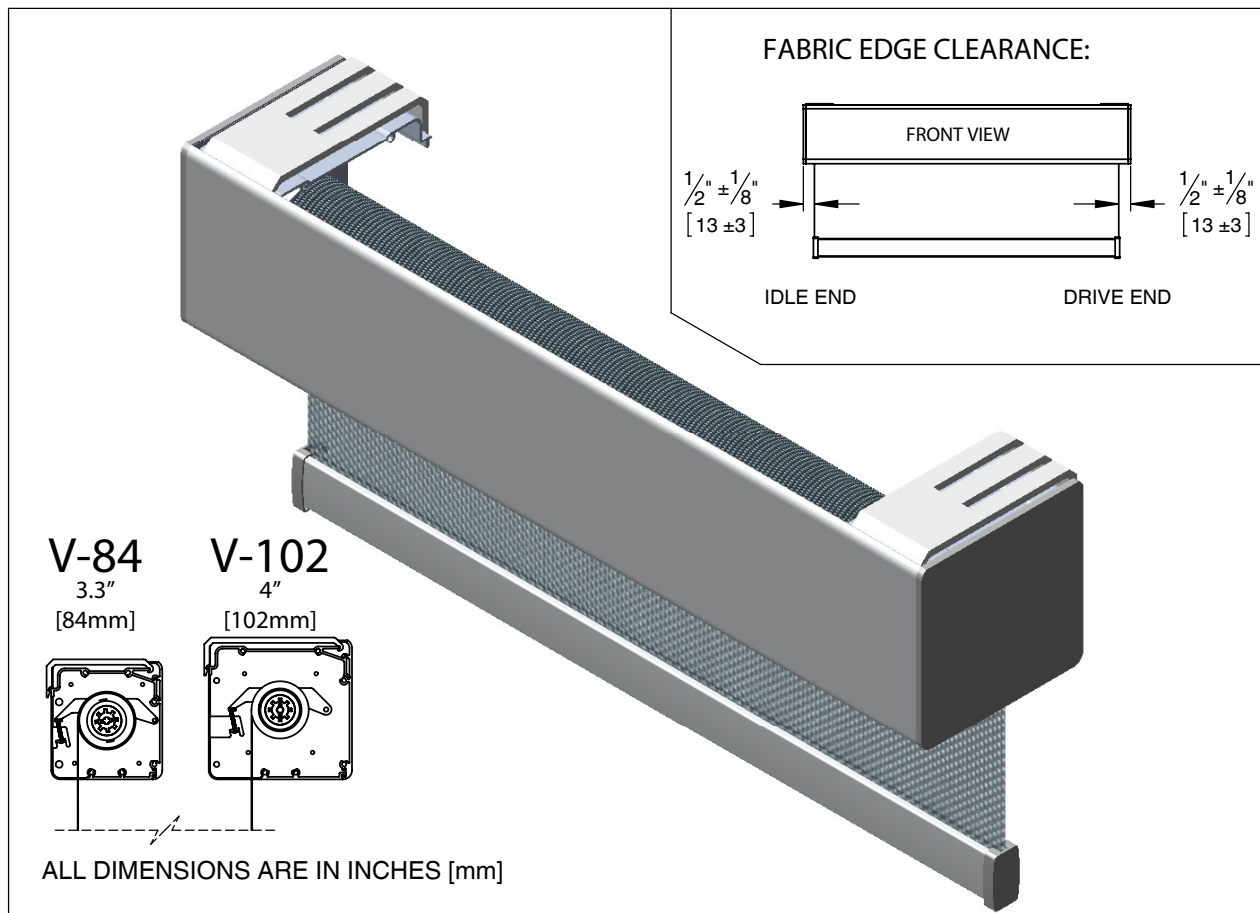

VISION™ ROLLER SHADE SYSTEMS

V-84 & V-102

Neo Chainless System: Features & Benefits



FEATURES	BENEFITS
CHAINLESS	SHADE IS OPERATED BY PULLING THE BOTTOM BAR, ELIMINATES CHAIN AND LIGATURE ISSUE
LIFT ASSIST MECHANISM (LAM) + NEO SPEED REDUCER	ALLOWS FOR SMOOTH OPERATION IN BOTH THE UP AND DOWN MOTION
SNAP-ON BRACKETS	QUICK AND EASY INSTALLATION & REMOVAL WITHOUT DISMANTLING THE SHADE
MODULAR DESIGN	WIDE VARIETY OF VALANCE CONFIGURATIONS FOR OPTIMAL PERFORMANCE & COST EFFECTIVENESS
MINIMAL & SYMMETRICAL LIGHT GAP	OFFERS GREATER SOLAR CONTROL AND A BALANCED APPEARANCE
COMPLETELY ASSEMBLED UNIT	SHADE IS BALANCED & TESTED DURING MANUFACTURING TO ENSURE PROPER PERFORMANCE BEFORE & AFTER INSTALLATION
BUILT IN LEVELLING SYSTEM	DRIVE & IDLE ENDS CAN BE LEVELED AFTER INSTALLATION TO COMPENSATE FOR UNEVEN MOUNTING CONDITIONS
VISION™ MEETS THE FOLLOWING LEED POINT CRITERIA	<ul style="list-style-type: none"> • MR CREDIT: 4.1/4.2 RECYCLED CONTENT • MR CREDIT: 5.1/5.2 REGIONAL MATERIALS • EQ CREDIT: 8.1/8.2 DAYLIGHT AND VIEWS
COLOUR OPTIONS	CASSETTE FINISHES AVAILABLE: WHITE, LINEN, ANODIZED, LIGHT BRONZE, DARK BRONZE, BLACK



VISION™ ROLLER SHADE SYSTEMS

V-84 & V-102

Neo Chainless System: Drive Mechanism

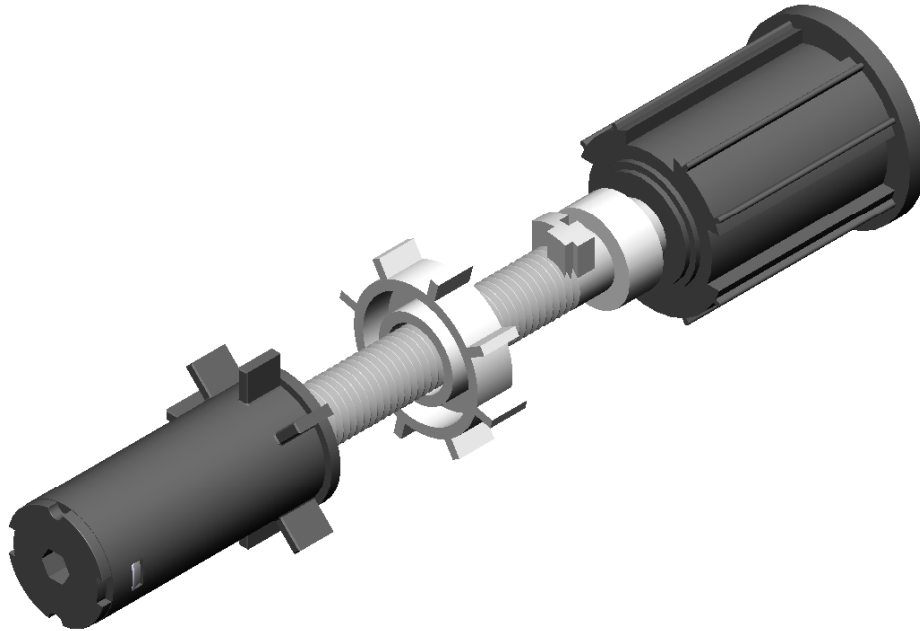

1.5" [38.1MM] NEO SPEED REDUCER - STANDARD

- DOES NOT REQUIRE CHAIN
- CAN EASILY BE OPERATED BY PULLING THE SHADE FROM THE CENTER OF THE BOTTOM BAR OR BLIND PULL TO THE DESIRED HEIGHT
- CAN EASILY BE RETRACTED BY A SLIGHT PULL OF THE BOTTOM BAR OR BLIND PULL
- SMART LOCK AND SNAP RELEASE ALLOW FOR EASY DISMOUNTING WHEN REQUIRED