

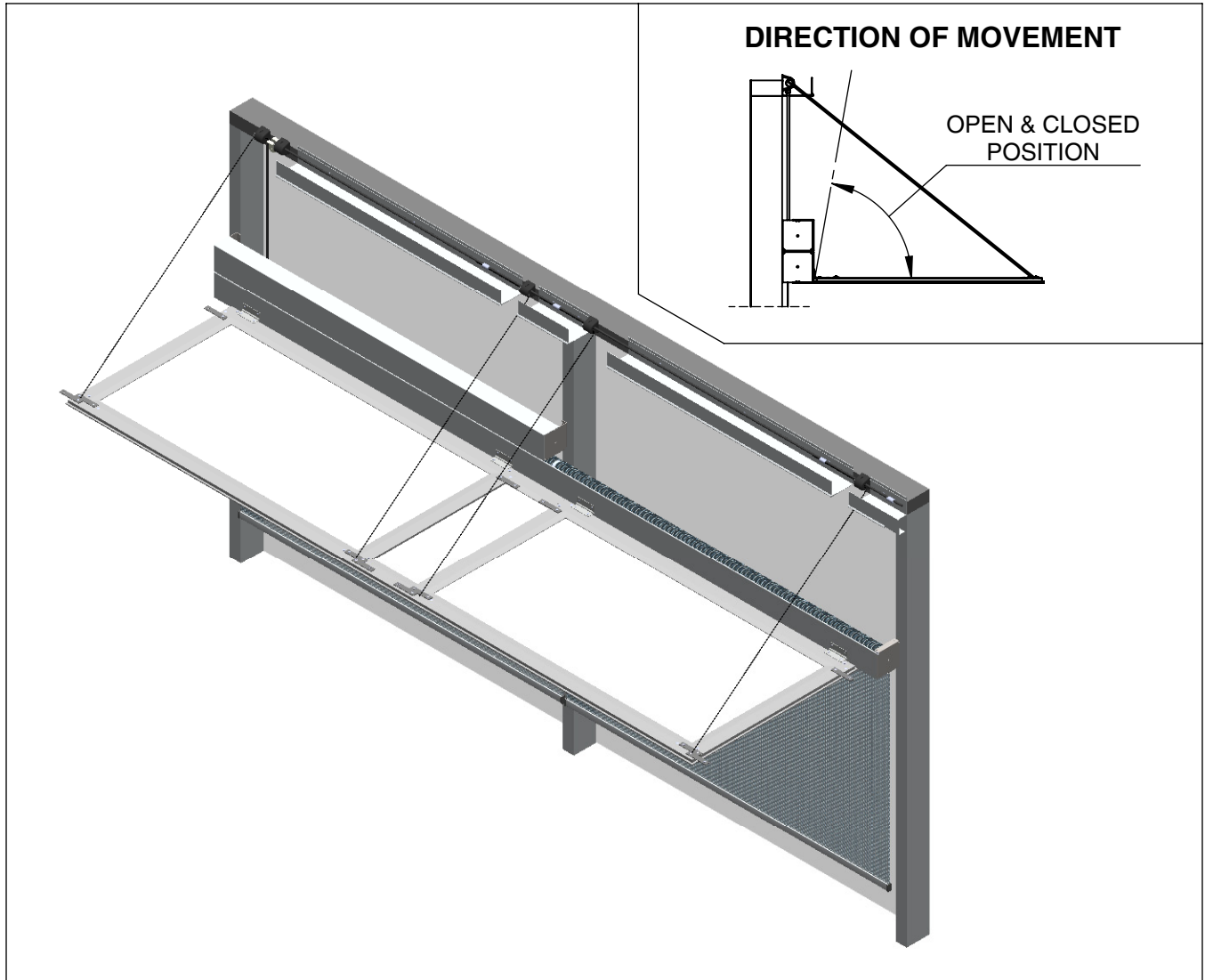

LIGHT SHELF

AUTOMATED LIGHT MANAGEMENT SYSTEM

FEATURES & BENEFITS



FEATURES	BENEFITS
DAYLIGHT CONTROL	LIGHT SHELF CAN BE POSITIONED TO OPTIMIZE THE AMOUNT OF LIGHT THAT ENTERS AN INTERIOR SPACE
ALUMINUM FRAME DESIGN	ABLE TO ACHIEVE WIDER WIDTH PANELS
POLYCARBONATE MATERIAL	LIGHT WEIGHT AND OFFERS FLEXIBLE LIGHT MANAGEMENT
ALUMINUM AIRCRAFT CABLE	STRONG AIRCRAFT CABLE PROVIDES A SMOOTH AND EFFORTLESS MOTION WHEN OPERATING THE LIGHT SHELF
MOTORIZED	INTEGRATED INTO BUILDING MANAGEMENT SYSTEM
INSERT (OPTIONAL)	INSERT BETWEEN EACH SHELF HELPS SHELF OPERATE TOGETHER AND CAN BE REMOVED FOR A DEMISING WALL IF NECESSARY
TOP CABLE COVER (OPTIONAL)	CABLE COVER HIDES AIRCRAFT CABLE AND PROVIDES A FINISHED LOOK

SCALE:	NONE	DWG NUMBER:	LS-M-01	DATE:	OCTOBER 7, 2015	REV:	0	DRAWN BY:	M.E.
--------	------	-------------	---------	-------	-----------------	------	---	-----------	------

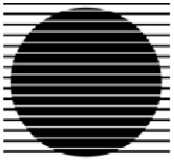

LIGHT SHELF AUTOMATED LIGHT MANAGEMENT SYSTEM

SUN GLOW TOP CABLE COVER (OPTIONAL)

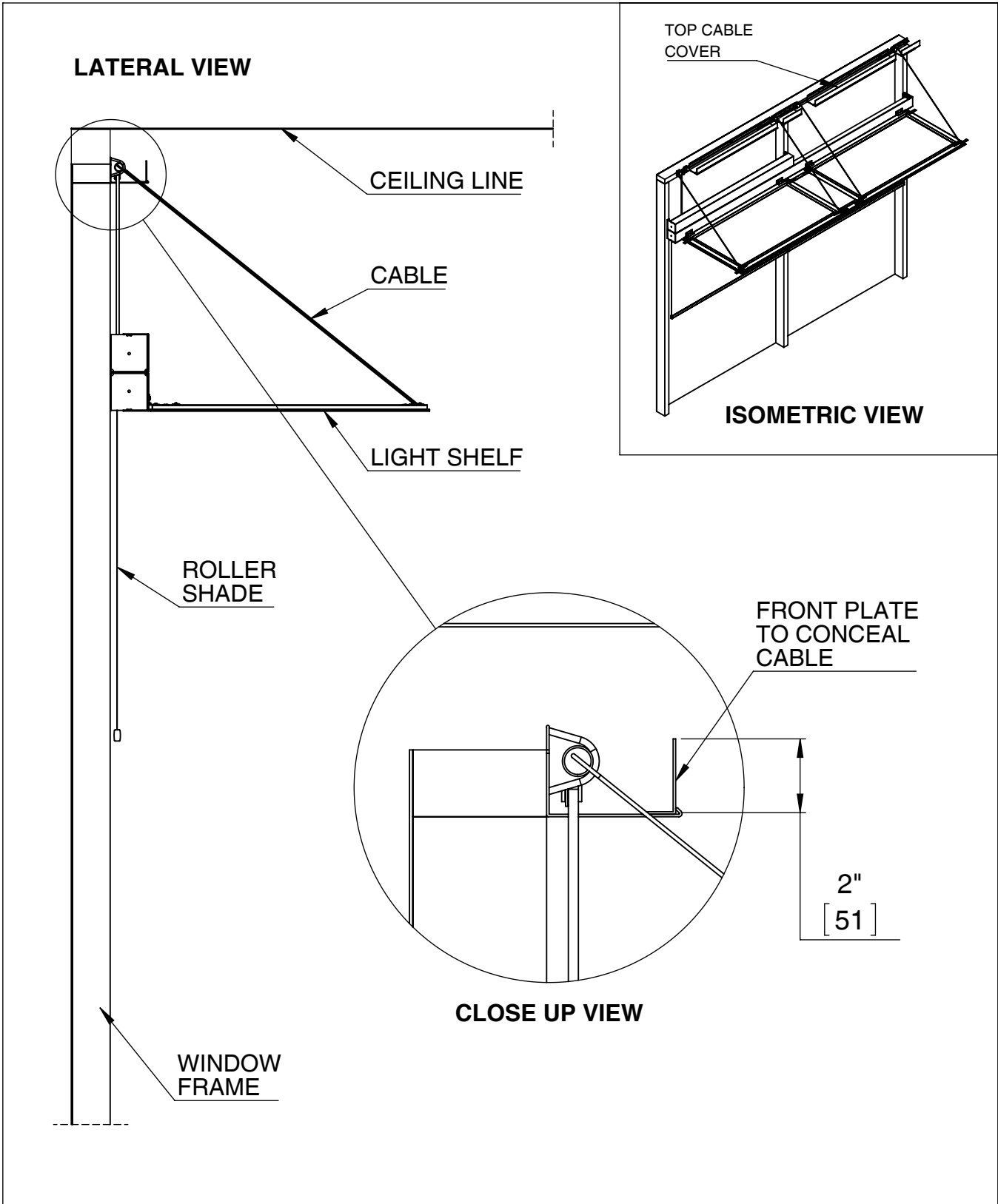

SCALE:	NONE	DWG NUMBER:	LS-FC-PLATE	DATE:	SEPTEMBER 30, 2015	REV:	1	DRAWN BY:	M.E.
--------	------	-------------	-------------	-------	--------------------	------	---	-----------	------



LIGHT SHELF

AUTOMATED LIGHT MANAGEMENT SYSTEM

DAYLIGHTING CONTROL

DOWN POSITION

LATERAL VIEW

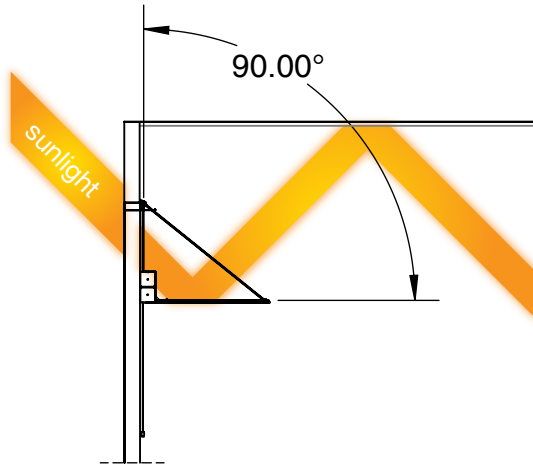

ISOMETRIC VIEW

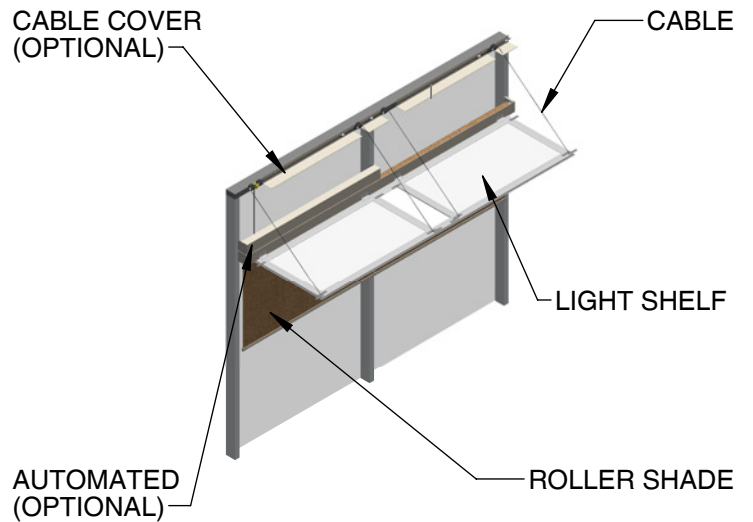

UP POSITION

LATERAL VIEW

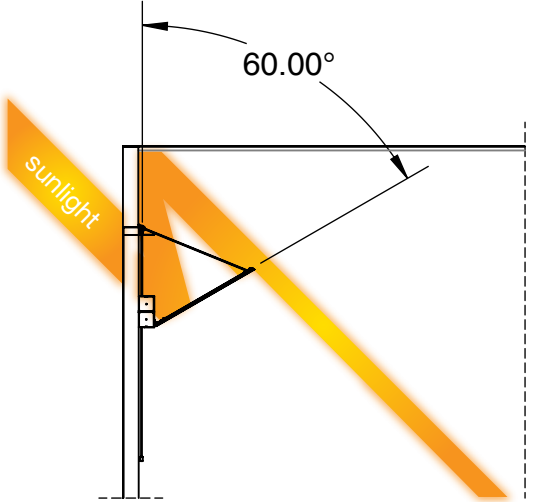

ISOMETRIC VIEW

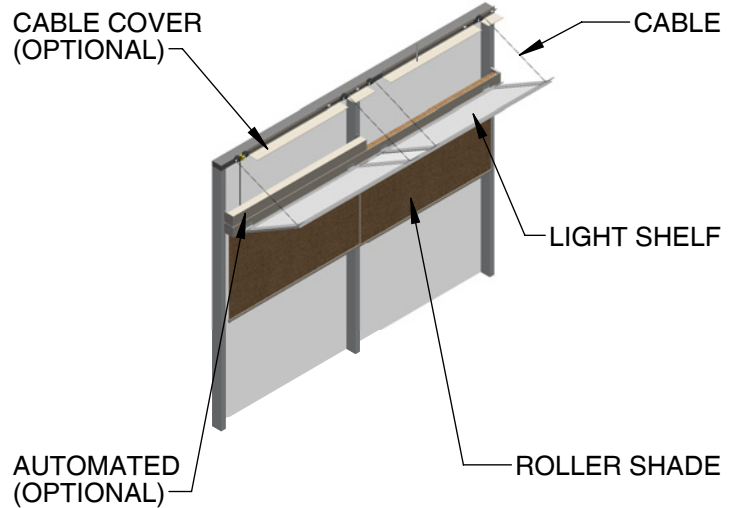

SCALE:	NONE	DWG NUMBER:	LSH-DL-01	DATE:	FEBRUARY 5, 2015	REV:	1	DRAWN BY:	M.E.
--------	------	-------------	-----------	-------	------------------	------	---	-----------	------